

DATE	PROJECT	FIRM	TYPE
------	---------	------	------

TROV MOUNTING ARMS ARE USED WHEN THERE IS NO STRUCTURE TO MOUNT THE FIXTURE AWAY FROM THE WALL.

FEATURES :

- COMPATIBLE WITH L35 AND L50 SERIES FIXTURES
- AVAILABLE IN 6", 12", 18" AND 24" LENGTHS
- MOUNTS TO ALL COMMON JUNCTION BOXES
- NO VISIBLE MOUNTING HARDWARE AND LEADER CABLE

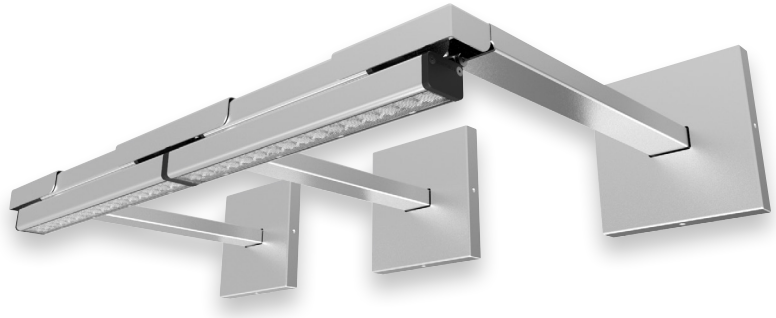

PHYSICAL

**DIMENSIONS
MATERIAL**

W 1.79" x H 2.31" x L 11.77" ; (45.5mm x 58.6mm x 299mm) APPROX
 END OF JOINING PLATES: CLEAR ANODIZED ALUMINUM; ARMS AND CANOPY, STEEL POWDER COATED SILVER

WALL MOUNT ARM FOR L35 AND L50

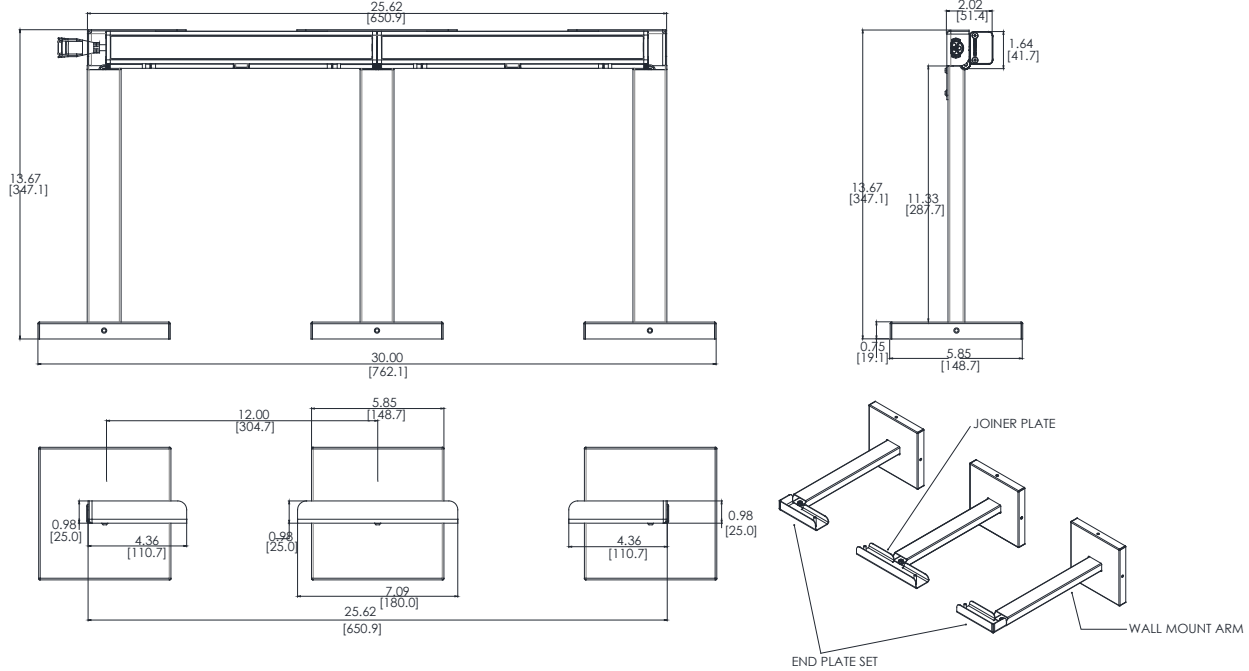

ORDERING

PART NUMBER	DESCRIPTION
WMA-L-CA-06	6 INCH WALL MOUNT ARM
WMA-L-CA-12	12 INCH WALL MOUNT ARM
WMA-L-CA-18	18 INCH WALL MOUNT ARM
WMA-L-CA-24	24 INCH WALL MOUNT ARM
WMA-L-END	WALL MOUNT ARM END PLATE SET
WMA-L-JNR	WALL MOUNT ARM JOINER PLATE

LIMITED WARRANTY 5 YEARS

ECOSENSE LIGHTING INC.
 915 WILSHIRE BLVD
 SUITE 2175
 LOS ANGELES, CA 90017

P • 310.496.6255
F • 310.496.6256
T • 855.632.6736
 855.6.ECOSEN

SPECIFICATIONS SUBJECT TO CHANGE WITHOUT NOTICE. VISIT ECOSENSELIGHTING.COM FOR THE MOST CURRENT SPECIFICATIONS.
 © 2018 ECOSENSE LIGHTING INC. ALL RIGHTS RESERVED. ECOSENSE, THE ECOSENSE LOGO, TROV AND ECOSPEC ARE REGISTERED TRADEMARKS OF ECOSENSE LIGHTING INC.

ECOSENSELIGHTING.COM

WALL MOUNT ARM FOR L35 AND L50

