

DATE	PROJECT	FIRM	TYPE
------	---------	------	------

TROV LANDSCAPE STAKES ARE IDEA FOR MOUNTING THE FIXTURE IN THE GRASS OR DIRT. THEY ARE TYPICALLY USED TO LIGHT SIGNAGE IN LANDSCAPES

**FEATURES :**

- COMPATIBLE WITH L35 AND L50 SERIES FIXTURES
- MOUNT DIRECTLY INTO THE GROUND
- AVAILABLE IN 6", 12" AND 18" ABOVE GROUND HEIGHTS



PHYSICAL	DIMENSIONS	MATERIAL
	W 2" x H 6/12/18" x L 2"; (50.8mm x 152.4/304.8/457.2mm x 50.8mm) APPROX	CLEAR ANODIZED ALUMINUM

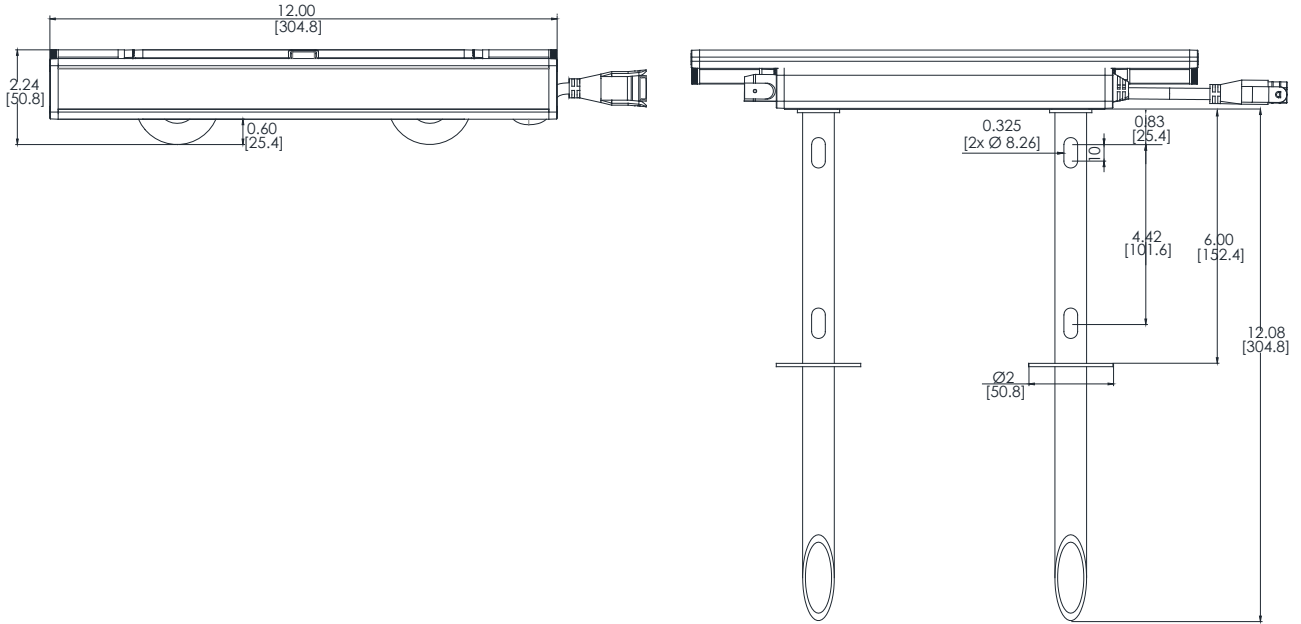

ORDERING

TYPE	MODEL/SIZE	FINISH	LENGTH
LS - LANDSCAPE STAKE	L	STK	06 - 6" 12 - 12" 18 - 18"

**EXAMPLE** LS-L-STK-06

**ONE SET OF LANDSCAPE STAKES INCLUDE TWO PIECES**

LIMITED WARRANTY 5 YEARS