



EcoSense Lighting Fixtures must be installed by a qualified electrician.

EcoSense Lighting, Inc. is not responsible if its fixtures are not installed in accordance with all national and local safety standards.

EcoSense Eclairage doit être installé par un électricien qualifié.

EcoSense Lighting, Inc n'est pas responsable si son appareils ne sont pas installés conformément à toutes les normes de sécurité nationales et locales.

INCLUDED / Inclus

RISE F080 Snoots Installation Guide / RISE F080 Installation - Coupe-flux Guide d'installation

*For other RISE Installation Guides visit www.ecosenselighting.com/downloads/rise

*Pour d'autres guides d'installation RISE, visitez www.ecosenselighting.com/downloads/rise

RISE F080 SNOOTS / RISE F080 Coupe-flux

- | | |
|---|---|
| <ol style="list-style-type: none"> 1. Loosen the two screws on the Back Bezel with a 2.5mm hex driver or key until the Front Bezel comes off. 2. Switch the clips to the open position. Replace the old lens and install the new lens. Refer to the lens installation instructions for specifics. Switch the clips to the closed position. 3. Attach the clips to the Front Bezel with the screws. Make sure the clips sit flush with Front Bezel. Tighten the rear screws to ensure a proper seal against the tertiary lens. Recommended Torque: 0.85 ± 0.15Nm. | <ol style="list-style-type: none"> 1. Dévisser les deux vis sur le cadran arrière avec un tournevis ou clé à six pans de 2,5 mm jusqu'à ce que le cadran avant se détache. 2. Déplacez les agrafes en position d'ouverture. Enlevez les anciennes lentilles et installez les nouvelles. Référez-vous aux instructions d'installation des lentilles pour les détails. Déplacez les agrafes en position de fermeture. 3. Fixer les pinces au cadran avant avec les vis. S'assurer que les pinces sont posées de niveau avec le cadran avant. Visser les vis à l'arrière pour assurer de créer un joint approprié avec la lentille tertiaire. Couple recommandé : 0,85 ± 0,15 Nm. |
|---|---|

FULL SNOOT / Plein Coupe-flux

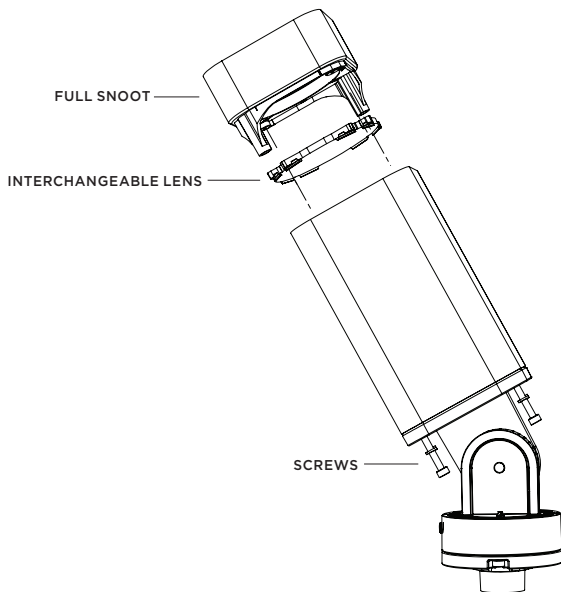

HALF SNOOT / Moitié Coupe-flux

