











## LED COMPONENT INFORMATION

- Fixture delivered light potential: 106 Lumens/Watt\*
- Uniform light distribution
- 90+ CRI LED diode options
- Exceptional binning- less than 2 step MacAdams Ellipse
- Minimum 70% initial lumen output at 70,000 hours
- Standard 0-10v dimming to %10
- Lutron, Eldoled, Dali, and other dimming options
- 5 year system warranty

\*Actual fixture efficacy will be dependent on specification. Higher lumens per watt are achieved with lower drive powers. Please contact the factory with questions or for more information.

## LUMEN OUTPUT\*

## LUMEN OUTPUT (PER FOOT)

DRIVER OUTPUT	DIRECT		INDIRECT	
	WATTAGE	LUMENS	WATTAGE	LUMENS
VERY LOW	4	425	4	420
LOW	6	645	6	640
STANDARD	8	845	8	835

## PER 4' FIXTURE (TOTAL DELIVERED LUMENS)

DRIVER OUTPUT	DIRECT		INDIRECT	
	WATTAGE	LUMENS	WATTAGE	LUMENS
VERY LOW	16	1,700	16	1,680
LOW	24	2,580	24	2,560
STANDARD	32	3,380	32	3,340

- **VERY LOW:** Considerably underdrives the LEDs to maximize fixture efficacy potential and limit wattage use.
- **LOW:** Underdrives the LEDs for reasonable light output while maintaining low wattage use.
- **STANDARD:** Drives the LEDs for the best combination of lumen output and fixture efficacy.

\*Lumen output will vary depending on ambient temperature. Cooler ambient and LED color temperatures result in higher luminaire performance. Calculations are based on 3500K LEDs.

## LUMINOUS INTENSITY DISTRIBUTION

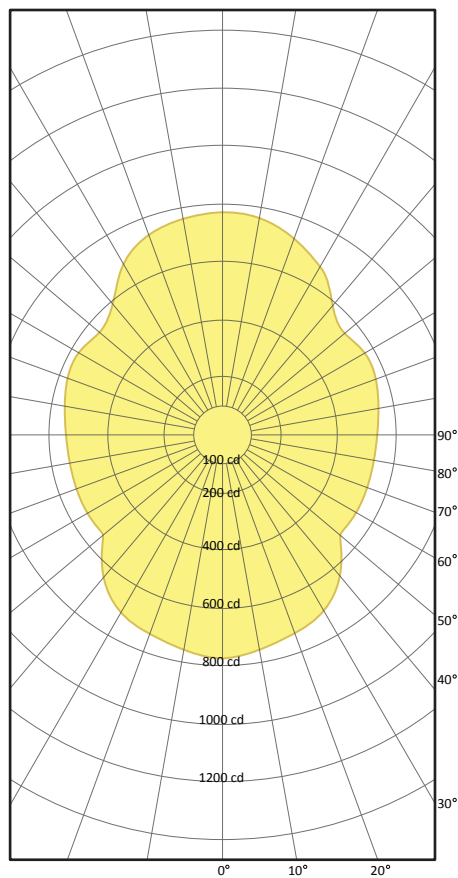

## FIXTURE PROPERTIES (AS TESTED)

- 4' nominal length fixture
- Standard Output (SO)
- Total system energy consumption: 64 Watt
- 106 Lumens/Watt
- 4000K 80 CRI LED

## ZONAL LUMEN SUMMARY

ZONE	LUMEN	%LAMP	%FIXTURE
0 - 30	616	7.1%	9.2%
0 - 40	1,031	11.9%	15.4%
0 - 60	1,911	22.1%	28.5%
0 - 90	3,306	38.3%	49.3%
90 - 120	1,439	16.7%	21.5%
90 - 150	2,766	32%	41.2%
90 - 180	3,403	39.4%	50.7%
0 - 180	6,708	77.7%	100%

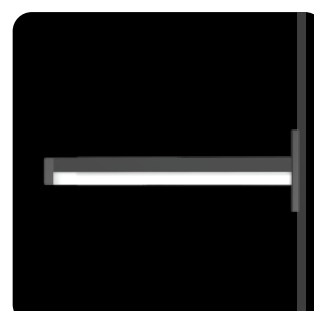
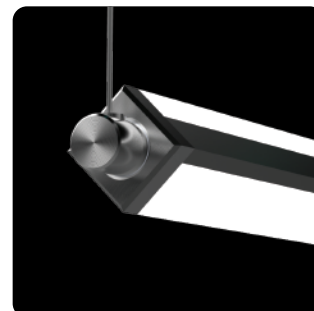
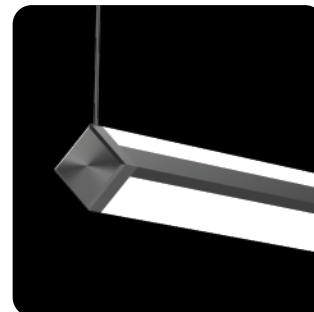

# REMOTE DRIVER HOUSING INFORMATION



## REMOTE DRIVER HOUSING SIZES

The driver housing length is typically dictated by the options selected. Standard driver housing lengths are as shown. Non standard driver requests may increase or decrease the driver housing length. Specifications are subject to change without notice. Consult factory with questions, requests, or size limitations and we will do our best to accommodate your needs.

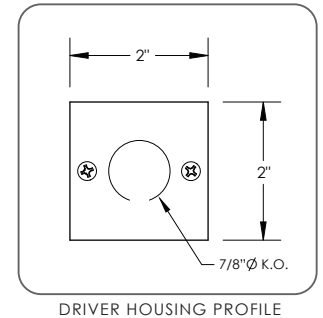
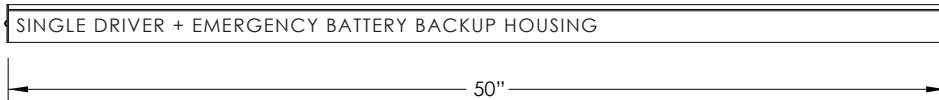
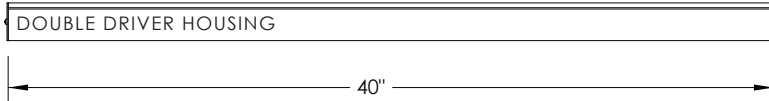
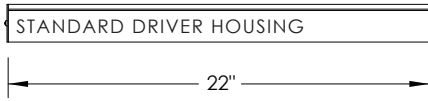

## INSTRUCTIONS

See below for lid removal and installation instructions.

To remove the driver housing lid, use a broad slot screwdriver in the channel as shown here and twist the screwdriver ninety degrees. This may need to be done at both ends of the housing or multiple locations depending on the driver housing length.

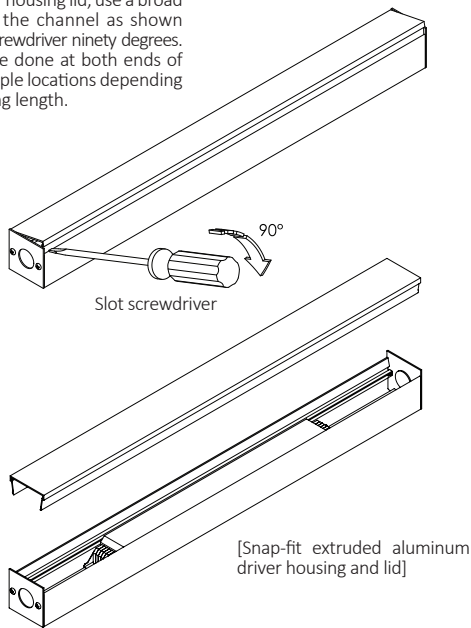

1) Drill mounting holes in the driver housing as needed to secure to a suitable surface. (If needed, a power feed hole can be drilled into the bottom of the housing for certain mounting/power feed applications).

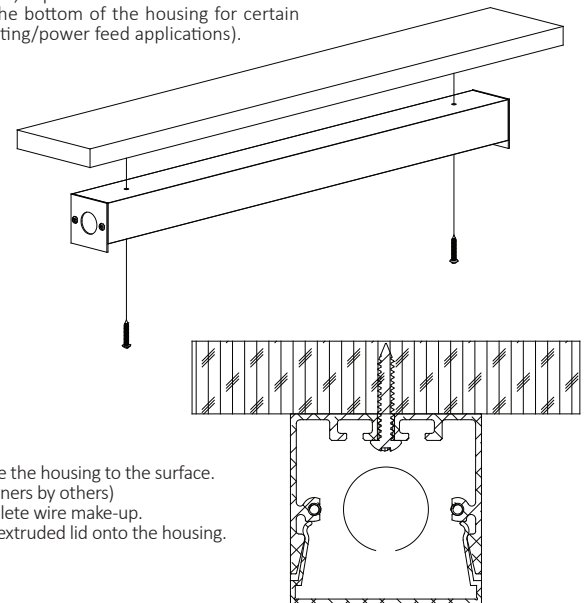

## FINISHES

Mill Aluminum (MA) is the standard finish. Satin White and Satin Black powder coat and Satin Clear anodized finishes can be done for a small charge. Custom finishes are possible. Contact the factory for specific finish options, specific requests, RAL colors, or any other questions.



Mill Aluminum (MA)  
[Standard finish]



Satin White (SW)  
[Upgrade finish]



Satin Black (SB)  
[Upgrade finish]



Satin Clear (SC)  
[Upgrade finish]



Custom Finish (CF)  
[Custom finish]



## NOTES

Other options are possible. Please contact the factory with custom requests.

Lumium Lighting, LLC | 3590 Cadillac Ave, Suite A, Costa Mesa, CA 92626 | Phone: 760.757.2530 | Fax: 760.283.2333 | [www.lumiumlighting.com](http://www.lumiumlighting.com)

While we always strive to ensure all website content and product information is current, Lumium Lighting reserves the right to change specifications without notice.  
© 2017 Lumium Lighting, LLC - All rights reserved.

0617



**Lumium**  
Lighting at its element

# OPTIONS GUIDE

## MOUNTING



### CABLE SUSPENDED (CS)

Powered Suspension System. Neutron (Nt) can be static larger down-light than up-light: Larger Aperture Direct (CSLAD), static larger up-light than down-light: Larger Aperture Indirect (CSLAI), static downlight ONLY: DIRECT (CSD), Vertical (CSV), or Rotational (see below). Standard and custom power cord finishes, sleeve options, and canopy colors offer options to match almost any space. Stainless steel cables come in various lengths (4' is standard) and are field adjustable.

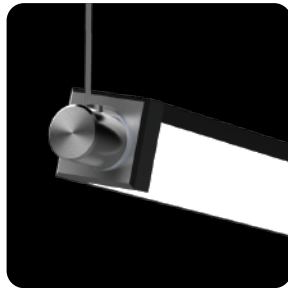

### CABLE SUSPENDED ROTATIONAL (CS-R)

Using a similar setup to the Cable Suspended system above, the Cable Suspended- Rotational system has 360 degree rotational capacity with mechanical fasteners to lock fixtures in place if desired. This system offers incredible flexibility, light direction control, and a dynamic aesthetic.

(360 DEGREE ROTATION)

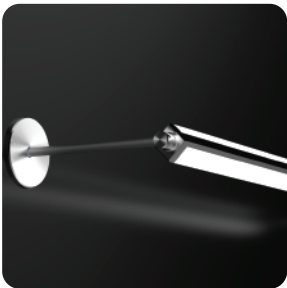

### ROTATIONAL ARM MOUNT (RAM)

This system uses 5/8" diameter aluminum arms and subtle details in combination with a 360 degree rotational capacity to create some of the most versatile linear fixtures in the architectural market. Standard mounting uses 3-O mud rings (supplied by others) or a 1" optional trim ring for furniture mounted applications. Engineered with no visible fasteners, smooth rotation, and mechanical locking, the RAM system reveals an impressive aesthetic with exceptional versatility.

(360 DEGREE ROTATION)

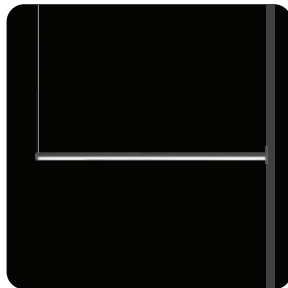

### END SURFACE MOUNT (ESM)

Wall Mount. Fixtures are mounted from their ends onto the wall using standard 3-O rings. The Neutron can be static larger down-light than up-light: Larger Aperture Direct (ESMLAD) or static larger up-light than down-light: Larger Aperture Indirect (ESMLAI). An aircraft cable suspension system will be issued if the fixtures are longer than 2 feet, if needed.

(LONGER THAN 2 FEET FIXTURE)



# OPTIONS GUIDE

## CONTINUOUS RUN

Continuous runs are available with all fixtures and have several connection options. Single Seam continuous run options offer smooth section transitions while Component Seams lend to a more dramatic visual statement. The 360 Rotational option enables individual sections to rotate independently of each other, which offers adjustable asymmetric light distribution capacity along with striking appearances such as alternating up/down fixtures or spiral transitions. The flexibility within the rotational option makes for infinite design and functional possibilities.



CONTINUOUS RUN  
SINGLE SEAM



CONTINUOUS RUN  
ROTATIONAL  
(SPIRAL EFFECT)



CONTINUOUS RUN  
ROTATIONAL

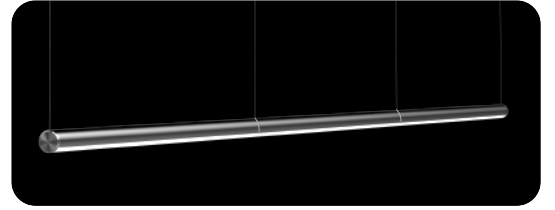

OXYGEN 2 (O2) WITH A SINGLE SEAM CONTINUOUS RUN

## CANOPIES

### STANDARD

Canopies have several standard options to suit various environment aesthetics. The standard cable suspension system has 5" Satin White canopies. However, other standard options include a 2" non-power feed canopy option as well as no canopy at all. Both of these include a 5" diameter power feed canopy.



5" diameter power feed and 5" diameter non-pow feed canopy. Most common canopy layout. Creates a consistent ceiling aesthetic.



5" diameter power feed and 2" diameter non-power feed canopy. Offers a more minimal ceiling treatment while maintaining the ability to cover up mistakes. Requires a 1/4-20 stud securely fastened to the ceiling.



5" diameter power feed canopy and no canopy on the non-power feed side. Minimal aesthetic. Requires a 1/4-20 stud securely attached to ceiling. Works well with continuous runs where the power can be carried inside the fixture.

### MACHINED

Machined canopies are 4" in diameter and can be anodized as well as powder coated to match a desired color or they can be left with a mill finish for a more striking look. Similar non-power feed options are available with this aesthetic as well. These options do carry a higher cost than standard canopies, but also have an impressive appearance.



4" diameter machined power feed and 4" diameter machined non-power feed canopy. Offers a consistent ceiling aesthetic with smaller machined canopies. Mill, anodized, and powder coat finishes available.



4" diameter machined power feed and 1-1/4" diameter machined non-power feed canopy. Offers minimal ceiling treatment while maintaining the ability to cover mistakes. Requires a 1/4-20 stud securely fastened to the ceiling. Mill, anodized, and powder coat finishes available.



4" diameter machined power feed canopy and no canopy on the non-power feed side. Minimal aesthetic. Requires a 1/4-20 stud securely attached to the ceiling. Works well with continuous runs where the power can be carried inside the fixture. Mill, anodized, and powder coat finishes available.

### CUSTOM

Custom canopies options are available and can look spectacular in certain applications. Contact the factory with all custom requests or with any questions.



CUSTOM POWDER COAT



CUSTOM ANODIZE



CUSTOM SHAPE



# OPTIONS GUIDE

## COLOR AND FINISH

Standard finish configurations are Satin Clear (SC) housing with Machined Finish (MF) machined components (end caps, knuckles, cover plates, etc.). The incredibly clean detail within all of the machined components lends to an incredibly high end aesthetic with two tone finish. Numerous custom anodizing and powder coated finishes are available as well. If you have a particular color/finish treatment in mind, please contact the factory and we will do our best to accommodate your project needs.

**STANDARD**

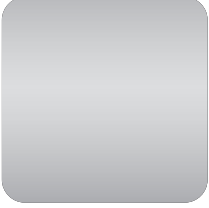

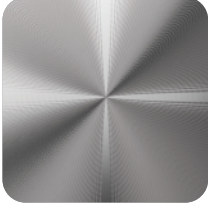

SATIN CLEAR ANODIZING





MACHINED COMPONENTS

**CUSTOM**

  
MATTE BLACK

  
GLOSS BLACK

  
BRONZE

  
MILL ALUMINUM

  
SPECULAR

  
SATIN WHITE

  
GLOSS WHITE

  
COLOR POWDER COAT

  
COLOR ANODIZE

  
RAL COLORS

**FINISHED CONFIGURATION**



THALLIUM 2 (Th2)

Cable Suspended Rotational mount system with two-tone finish, Satin Clear housing and Machined Finish components.

## COVER PLATES

Cover plates are standard for Rotational Arm Mounting (RAM) Systems. Standard options are Flat (FT), Curved (CV), or Trim Ring (TR). With certain applications, cover plates or trim rings may not be necessary. Contact factory with questions or for more information. Custom cover plates are also available. If a certain aesthetic is desired, please contact the factory to review any concepts and we will do our best to bring your vision to life.

**STANDARD**

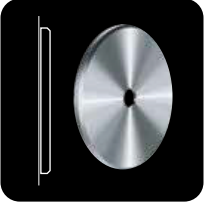

**FLAT (CPFT)**  
Flat has a 4" diameter cover plate for use with a 3-O mud ring.

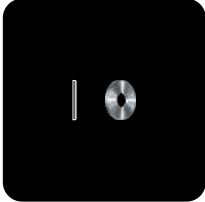

**TRIM RING (TR)**  
1-1/4" diameter trim ring  
Can be used in applications such as desk mounting.

**CUSTOM**

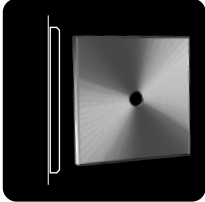

SQUARE

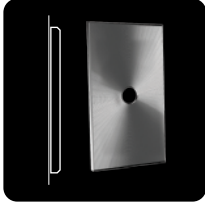

TALL RECTANGLE



CUSTOM

