

Coverd Light Leakage

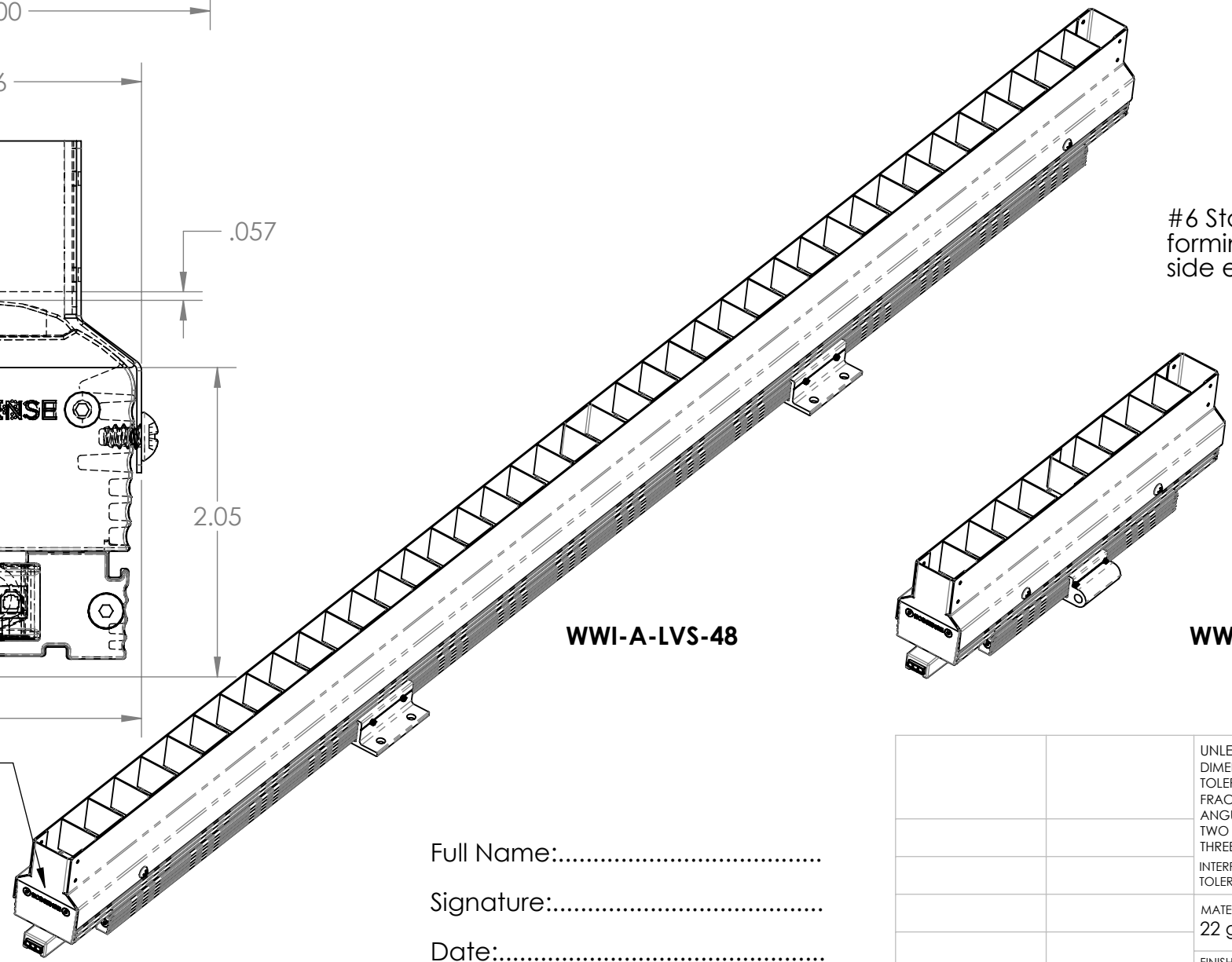

WWI-A-LVS-48

WWI-A-LVS-12

#6 Stainless Steel Thread forming Screw grips in side extrusion (x 4)

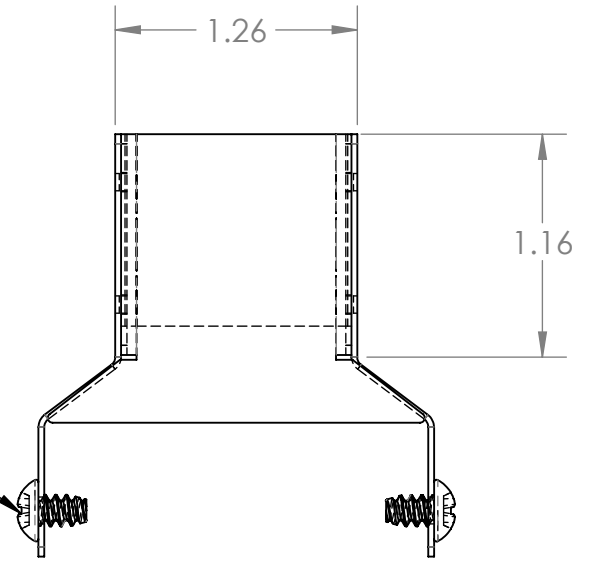

DETAIL A  
SCALE 1 : 1

Full Name:.....  
Signature:.....  
Date:.....

		UNLESS OTHERWISE SPECIFIED: DIMENSIONS ARE IN INCHES TOLERANCES: FRACTIONAL ± ANGULAR: MACH ± BEND ± TWO PLACE DECIMAL ± THREE PLACE DECIMAL ± INTERPRET GEOMETRIC TOLERANCING PER:		NAME	DATE	
		DRAWN	TB	12/25/2013	TITLE:	
		CHECKED			WWIX Symmetrical Louver	
		ENG APPR.			SIZE	
		MFG APPR.			DWG. NO.	
		Q.A.			REV	
		FINISH Powder Coat Flat Black		COMMENTS:		02
NEXT ASSY	USED ON					SCALE: 1:8
APPLICATION		DO NOT SCALE DRAWING				SHEET 1 OF 1

PROPRIETARY AND CONFIDENTIAL: THE INFORMATION CONTAINED IN THIS DRAWING IS THE SOLE PROPERTY OF ECOSENSE LIGHTING INC. ANY REPRODUCTION IN PART OR AS A WHOLE WITHOUT THE WRITTEN PERMISSION OF ECOSENSE LIGHTING IS PROHIBITED.