

8 7 6 5 4 3 2 1

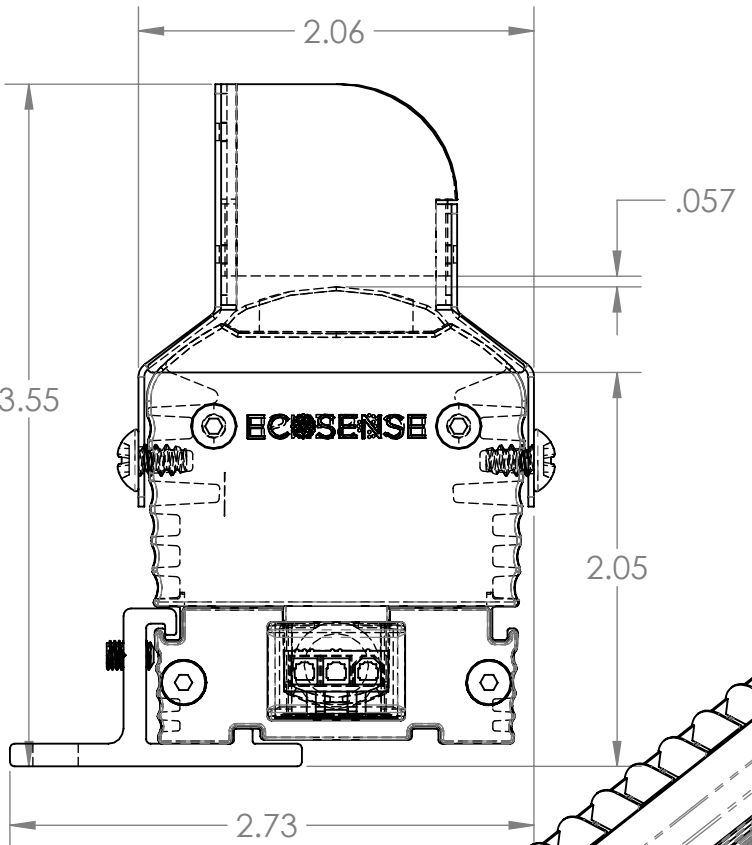

#6 Stainless Steel Thread forming Screw grips in side extrusion (x 4)

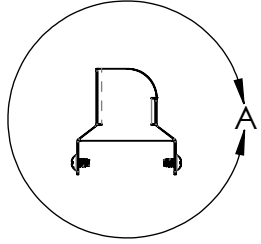
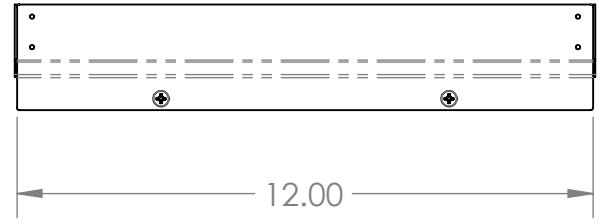
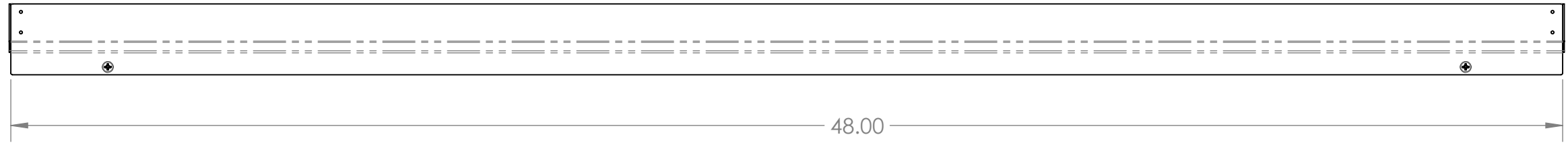
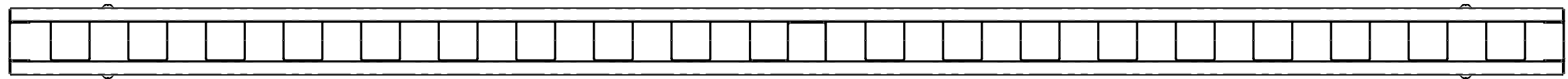
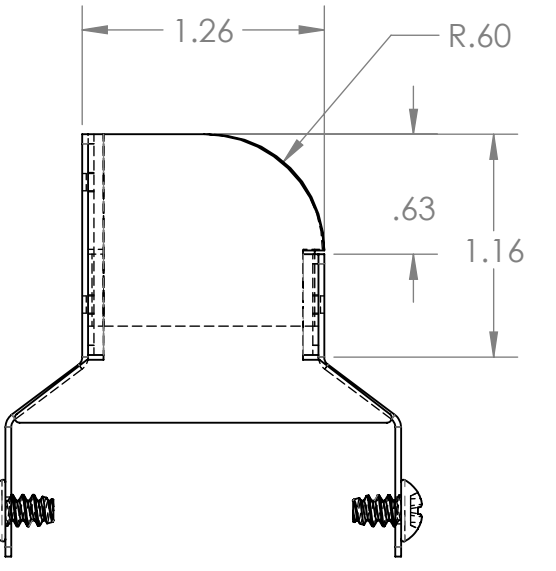

DETAIL A
SCALE 1 : 1

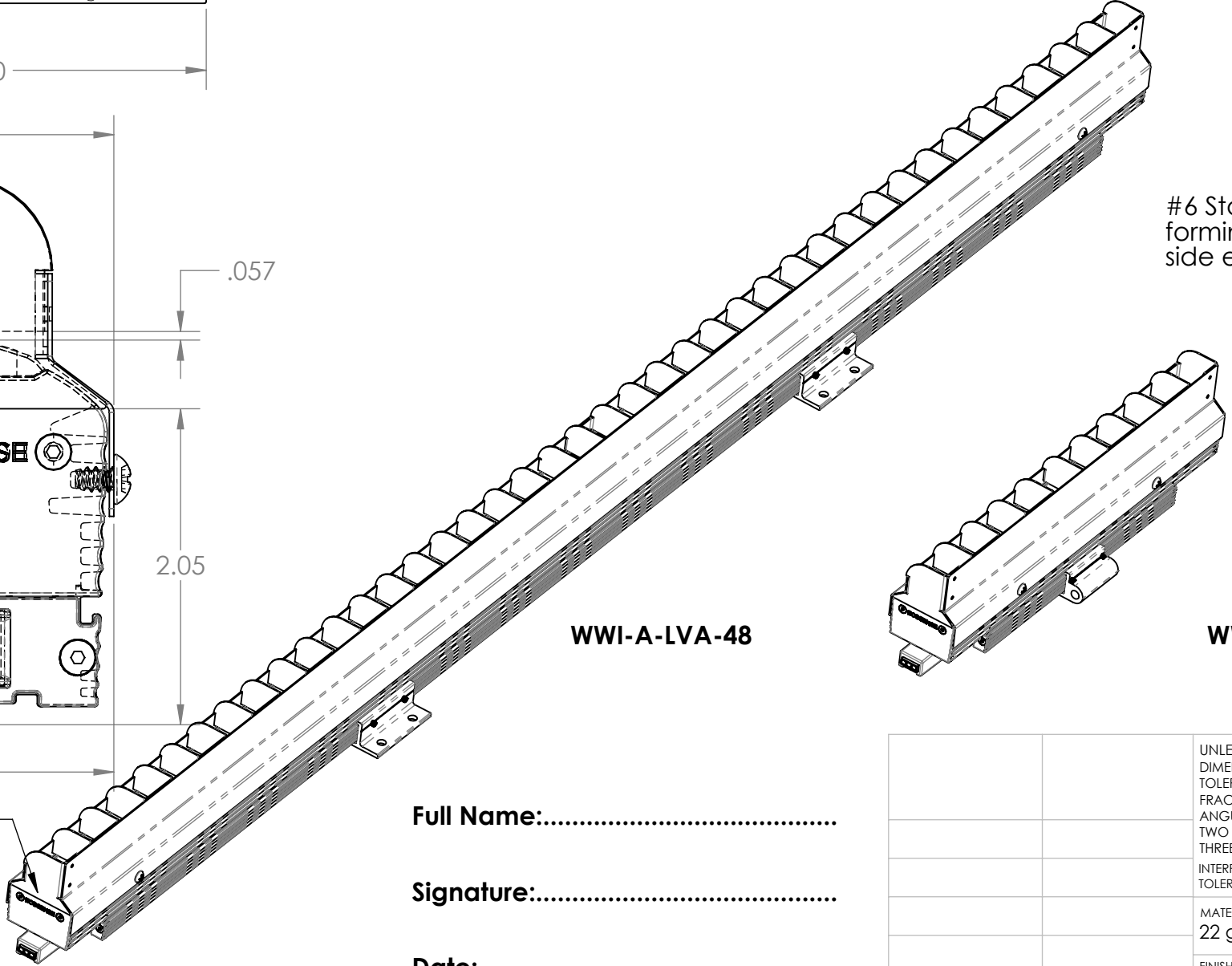

WWI-A-LVA-48

WWI-A-LVA-12

Coverd Light Leakage

Full Name:.....
Signature:.....
Date:.....

		UNLESS OTHERWISE SPECIFIED: DIMENSIONS ARE IN INCHES TOLERANCES: FRACTIONAL ± ANGULAR: MACH ± BEND ± TWO PLACE DECIMAL ± THREE PLACE DECIMAL ± INTERPRET GEOMETRIC TOLERANCING PER:		NAME	DATE	ECOSENSE™
		MATERIAL 22 ga EGS	FINISH Powder Coat Flat Black	DRAWN TB	12/25/2013	
NEXT ASSY	USED ON			CHECKED		SIZE DWG. NO. REV B WWI-A-LVA-48 02
APPLICATION		DO NOT SCALE DRAWING		ENG APPR.		SCALE: 1:8 SHEET 1 OF 1
				MFG APPR.		
				Q.A.		
				COMMENTS:		

8 7 6 5 4 3 2 1